



Hotspot Gateway Product Setup - Quick Start Guide 1

Download the product manual at: <http://www.guest-internet.com/gateway>

All guest Internet wireless products operate the same way. Each product is designed for a specific type of installation so that the best performance can be obtained.

Guest Internet wireless units should be connected as shown in the diagrams. Use ONLY the power supply shipped with each unit. Different models have different power supply voltages. Swapping power supplies will damage the wireless units. The K1 unit must be installed. See other products for installation outdoors. Guests can use any type of WiFi device, such as a laptop, to connect to the Internet, however some products may require configuration.

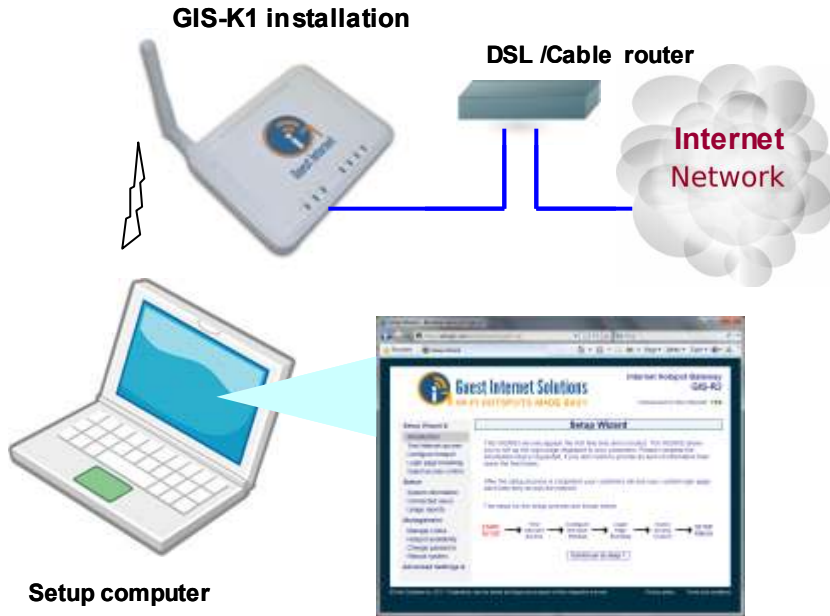

The K1 is shipped with a 2dBi rubber duck antenna. Other antennas can be connected using the RP-SMA connector. Guests obtain the best connection results when their laptop computers have a direct line of sight to the wireless unit antenna. When the signal has to go through walls indoors, or trees outdoors then the communications range will be reduced. Guest Internet can provide a wireless range extender to increase the area of wireless coverage

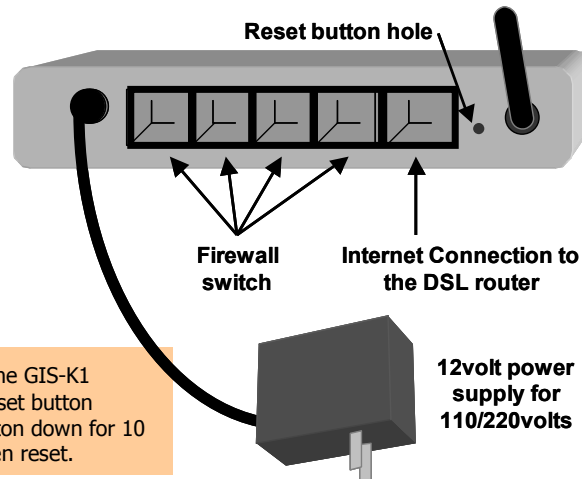

Reset to Factory Defaults: With the GIS-K1 powered up, use a paperclip to press the reset button through the hole shown. Hold the reset button down for 10 seconds the release. All parameters has been reset.

First Time Product Configuration

Using your laptop computer select the wireless network option and scan for networks. The computer will display a list of wireless networks. Look for wireless network name (SSID): **Hot Spot**. Click on **connect**, wait until the computer shows **connected**. Open your computer browser. Instead of your login page you will see the page shown below. This page is the SETUP WIZARD.



The setup process has four steps. Follow the instructions to type in the information requested on each page. Then click on the button to go to the next page. When the setup process is completed your personalized wireless Internet service will be ready for your guests to start using. The setup process is shown overleaf: flip this page over to start the setup process.

You can return to the setup process at any time to change information. Connect you laptop computer to the wireless name (SSID) that you have chosen. Then open your browser and type in the URL:
<http://aplogin.com/admin>

The username is **admin**, and the password is **admin** or a password that you selected. When the page opens select the option you need in the menu. See the manual for more information about configuration.

Step 1: test the Internet access

Your gateway unit **must have** a connection to the Internet for the configuration process to be completed. If you see a green YES then proceed to step 2. If a red NO then click on the link to diagnose the problem.

You may have to set a 'fixed IP'. If you are not familiar with setting a fixed IP then ask a network technician to provide help with this.

Some DSL and Cable routers have a firewall setting that prevents the gateway connecting to the Internet. You may have to change a setting on the router firewall.

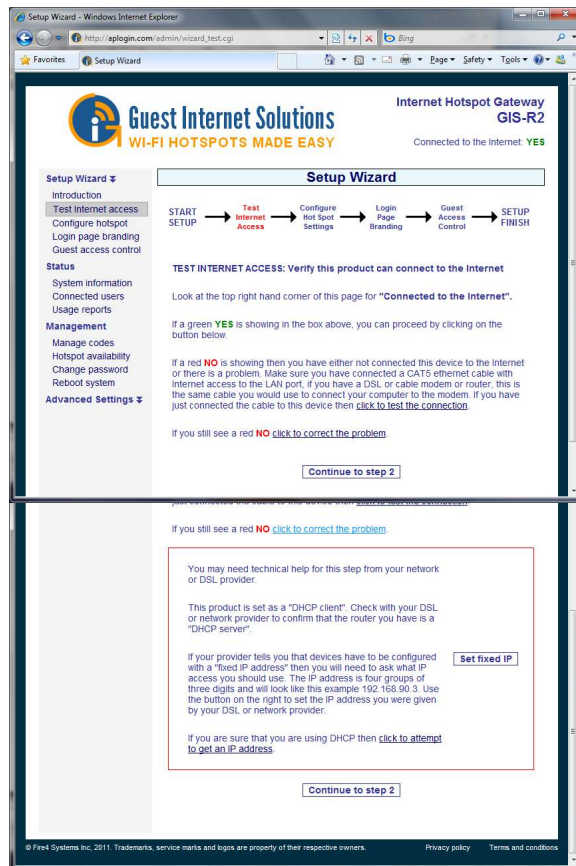

Step 2: configure hotspot settings

Select your time zone, wireless Hotspot name and set your password. Note your password and keep in a safe place.



Step 3: login page branding

Your guests will see this information on the login page



Step 4: select guest access

If you select unlimited access then your guests will click on a disclaimer to access the Internet. If you select controlled access then you will have to generate access codes for your guests.

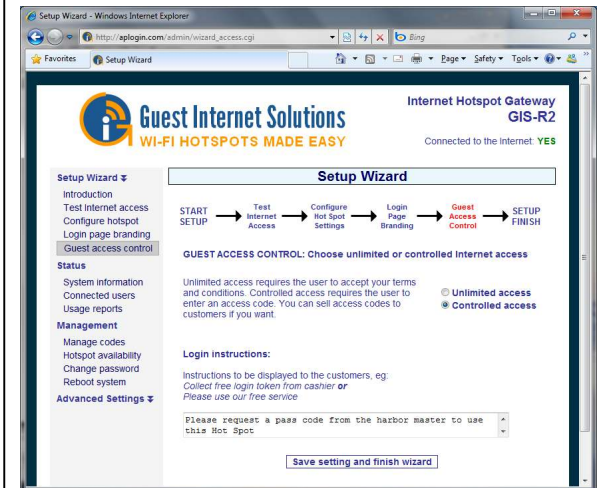

Finished, click on reboot to start your hotspot

After reboot wait two minutes then open your browser to see your login page. If you want to make changes then login again and click on the setup wizard.

